









KILAVUZ - PAFTA TAKIMI HSS

KOD	ÖLÇÜ ARALIĞI	ÖLÇÜ
NB-986	M3-M12	M3-M4-M5-M6-M8-M10-M12
NB-987	M12-M20	M12-M14-M16-M18-M20
NB-987W1	W1/8"-W1/2"	W1/8-3/16-1/4-5/16-3/8-7/16-1/2 (CS)
NB-987W2	W1/2"-W1"	W1/2-9/16-5/8-3/4-7/8-1 (CS)
NB-988UNC1	UNC1/4"-UNC1/2"	UNC1/4-5/16-3/8-7/16-1/2 (CS)
NB-988UNC2	UNC1/2"-UNC1"	UNC1/2-5/8-3/4-7/8-1 (CS)
NB-989UNF1	UNF1/4"-UNF1/2"	UNF1/4-5/16-3/8-7/16-1/2 (CS)
NB-989UNF2	UNF1/2"-UNF1"	UNF1/2-5/8-3/4-7/8-1 (CS)
NB-990G	G1/8"-G1"	G1/8-1/4-3/8-1/2-5/8-3/4-7/8-1 (CS)



KILAVUZ - PAFTA TAKIMI HSS (HOBBY SET)

KOD			
	M 3; 4; 5; 6; 8; 10; 12	2,5-7,1 mm	
NB-985			
	M 3; 4; 5; 6; 8; 10; 12	Ø 2,5; 3,3; 4,2; 5; 6,8; 8,5; 10,2	
			
	Ø 25 mm		



KILAVUZ - PAFTA TAKIMI HSS

KOD	ÖLÇÜ ARALIĞI	ÖLÇÜ
C.986	M3-M12	M3-M4-M5-M6-M8-M10-M12
C.987	M12-M20	M12-M14-M16-M18-M20
C.988	M3-M24	M3-M4-M5-M6-M8-M10-M12-M14-M16-M18-M20-M22-M24



OTOMATİK KILAVUZ ÇEKME APARATI

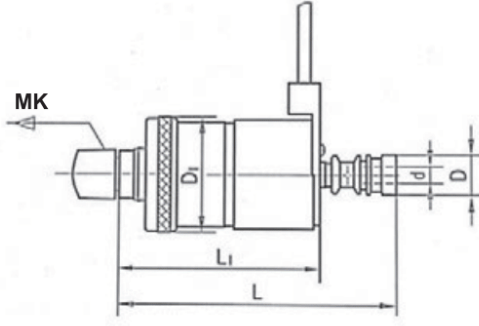

OTOMATİK KILAVUZ ÇEKME APARATININ MONTAJI:

- 1- Kılavuz çekme aparatı mors konik kısmından matkap fener miline bağlanır
- 2- Kılavuz uygun pens kullanılarak kılavuz çekme aparatına monte edilir. Bu işlem sırasında kılavuzun kare kesitli kısmının mekanik kılavuz çekme aparatı üzerindeki yuvasına allen anahtar yardımıyla bağlanması gerekmektedir.
- 3- Dayama pimi matkap tezgahı çalıştığında sabit kalacak şekilde başka bir dayama pimine (matkap tezgahı gövdesindeki bir dayamaya, matkap tablasına bağlanan saplamaya vs.) dayanır.

OTOMATİK KILAVUZ ÇEKME APARATIYLA DIŞ ÇEKME:

- 1- İş parçası matkap tablasına, kılavuz eksenini ve dış çekilecek delik eksenini çıkışacak şekilde sabitletir.
- 2- Matkap tezgahı dış çekme yönünde çalıştırılır.
- 3- Matkap talaş verme kolu kılavuz dış çekilecek deliği ağızlayınca kadar aşağı doğru çevrilir.
- 4- Kılavuz istenilen boyda dış çekme işlemini tamamlayınca kadar matkap talaş verme kolu aşağı doğru çevrilmeye devam edilir.
- 5- Kılavuz istenilen boyda dış çekme işlemini tamamlayınca matkap talaş verme kolu yukarı doğru çevrilir. Bu işlem sırasında mekanik kılavuz çekme aparatının pens kısmı aparattan dışarı doğru çıkacaktır ve sadece pens kısmı dış çekme yönünün tersi yönde dönmeye başlayacaktır.
- 6- Kılavuz delikten kurtulunca pens kısmı yaylı mekanizması sayesinde eski konumunu alacaktır ve tekrar dış çekme yönünde dönecektir

ÖLÇÜ	d(mm)	D (mm)	D ₁ (mm)	L (mm)	L ₁ (mm)	MK
M2-M7	2.5-6.5	23	55	135	95	MK2-MK3
M5-M12	3.5-10	28	75	164	114,5	MK3-MK4
M8-M20	6.3-14	38	90,5	205	135	MK3-MK4

OTOMATİK KILAVUZ ÇEKME YEDEK PENSLER

KOD	ÖLÇÜ
C006-207P	M2-M7 İÇİN YEDEK PENS (2'Lİ SET)
C006-512P	M5-M12 İÇİN YEDEK PENS (2'Lİ SET)
C006-820P	M8-M20 İÇİN YEDEK PENS (2'Lİ SET)



TERS KILAVUZ TAKIMLARI HSS



KOD	ADET	ÖLÇÜ
C345-5	5 PARÇA	M3-M6/M6-M8/M8-M11/ M11-14/M14-M18
C345-6	6 PARÇA	M3-M6/M6-M8/M8-M11/M11-14/M14-M18/M18-24
C345-8	8 PARÇA	M3-M6/M6-M8/M8-M11/M11-14/M14-M18/M18-24/M24-M30/M30-M40

ÇELÝK KILAVUZ KOLU

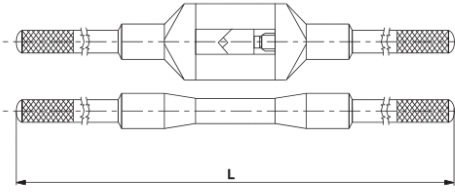

KOD	L (mm)	ÖLÇÜ (mm)
C350-00S	170	0 (M1 - M8)
C350-15S	200	1-1/2 (M1 - M12)
C350-20S	255	2 (M4 - M12)
C350-30S	345	3 (M5 - M20)
C350-40S	425	4 (M9 - M27)
C350-50S	765	5 (M13 - M32)
C350-60S	870	6 (M20 - M40)

ÇELÝK KILAVUZ KOLU

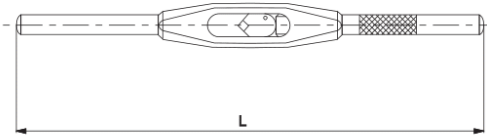

KOD	L (mm)	ÖLÇÜ (mm)
NB-350-15S	125	1-1/2 (M2 - M7)
NB-350-20S	210	2 (M3 - M12)
NB-350-30S	310	3 (M6 - M14)
NB-350-40S	400	4 (M9 - M27)
NB-350-50S	400	5 (M10 - M30)
NB-350-60S	500	6 (M24 - M52)

ÇİRCİRLİ KILAVUZ KOLU

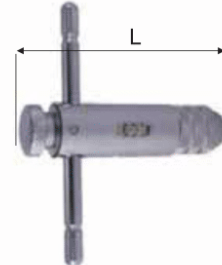
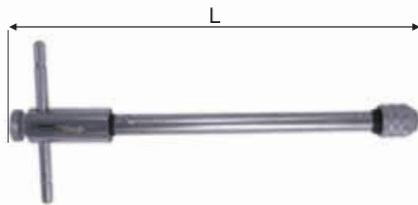

KOD	L (mm)	ÖLÇÜ (mm)
C341-10	85	1 (M3 - M8)
C341-20	110	2 (M5 - M12)
C341-100	250	10 (M3 - M8)
C341-200	310	20 (M5 - M12)

PAFTA KOLU

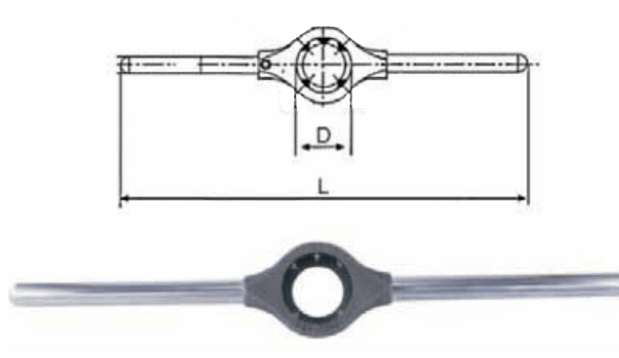

KOD	D (mm)	L (mm)
NB-40320	20	170
NB-40325	25	210
NB-40330	30	270
NB-40338	38	325
NB-40345	45	400
NB-40355	55	475
NB-40365	65	555

PAFTA KOLU

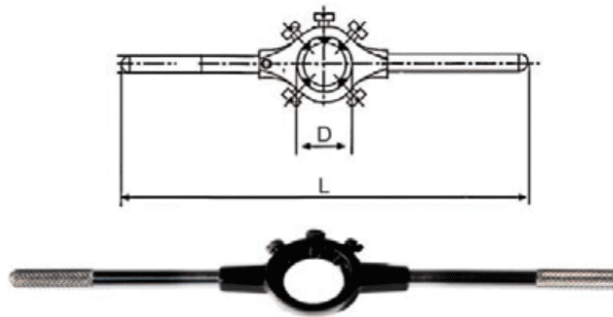

KOD	D (mm)	L (mm)
C351-20	20	175
C351-25	25	210
C351-30	30	255
C351-38	38	300
C351-45	45	450
C351-55	55	490
C351-65	65	550
C351-75	75	550
C351-90	90	800
C351-105	105	900